

TREMSAFE GUARDRAIL A.S.

Safety Precautions

- Personnel using this product must be trained on proper and safe installation.
- The load limit of the installation surface must be checked to ensure that the surface can tolerate the weight of the TremSafe Guardrail A.S. system and installation personnel.
- TremSafe Guardrail A.S. is designed to be used only on flat surfaces, free of debris.
- Never use TremSafe Guardrail A.S. on slick surfaces.
- Never set up TremSafe Guardrail A.S. near electrical wires. The rails must be at least five feet from power lines.
- Never use damaged rails or gates. Inspect all product to ensure there is no damage. If any product is damaged, replace with new product.
- Always use an outrigger at the beginning and end of a continuous run or any interruption in a run. The outrigger should be positioned approximately at a 90 degree angle to the run.
- Never use TremSafe Guardrail A.S. rails for hoisting.
- Verify that the bottom of the base has four rubber pads. Install new pads if any are missing.
- Bases must be placed at a minimum of 18" away from the leading edge where there is no curb or parapet on a leading edge. Bases may be placed next to the vertical rise if a curb or parapet is present.

Installation Instructions

PLEASE NOTE: A minimum of two people are required for installation.
All set screws must be tightened to 24 lb-ft of torque.

- 1) Place the bases as shown on the supplied installation drawing.
- 2) If an installation drawing was not supplied, use the following steps.
 - a. Place a base at each corner.
 - i. A minimum clearance of 21" is required to add returns.
 - ii. A minimum clearance of 21" is also required when continuing a run at 90 degrees.
 - b. Measure the distance between the center of the corner bases and divide the distance by the maximum distance allowed.
 - i. OSHA maximum distance allowed is 10 feet.
 - ii. California OSHA maximum distance allowed is 8 feet.
 - iii. The result will give you the number of bases needed for the run.
 - c. The number of bases needed must be rounded up if there is a decimal place.
 - i. Divide this number into the measured distance.
 - ii. The result will give the spacing between bases.
 - d. Place the bases as required for the rail run.
 - e. Refer to the example below:

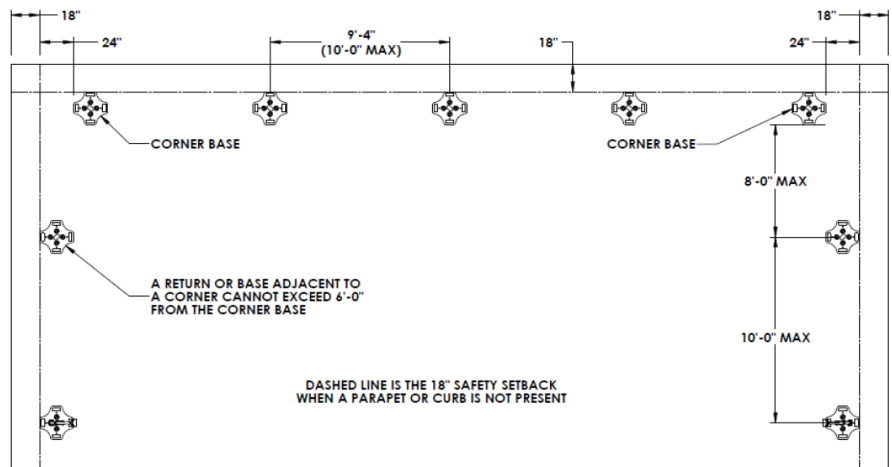

TREMSAFE GUARDRAIL A.S.

Installation Instructions

PLEASE NOTE: Always start the assembly on one end of the guardrail set up and work to the other end.

- 3) Insert stanchions into the receiver ports nearest the fall hazard and secure them to the bases by installing securing pins.
 - a. If the stanchions are angled or curved, the stanchions must be installed with the radius or angle oriented away from the fall hazard.

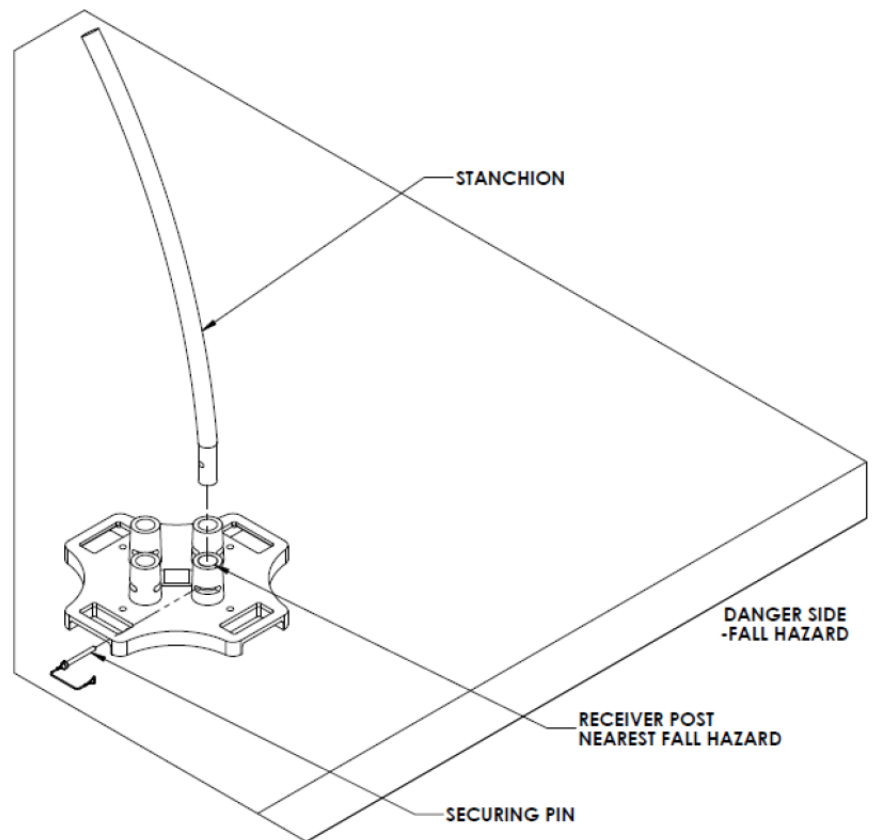

TREMSAFE GUARDRAIL A.S.

INSTALLATION INSTRUCTIONS

- 4) PLEASE NOTE: The edge of the cradle fittings must be parallel to the back edge of the bases during installation.
- 5) Install cradle fittings onto the stanchions and adjust height to 21" from the roof top.
 - a. Tighten the set screws.
- 6) Install a second cradle fitting onto the stanchions and adjust height to 42" from the roof top.
 - a. Tighten the set screws.
- 7) Press an end cap plug into the top of each stanchion.

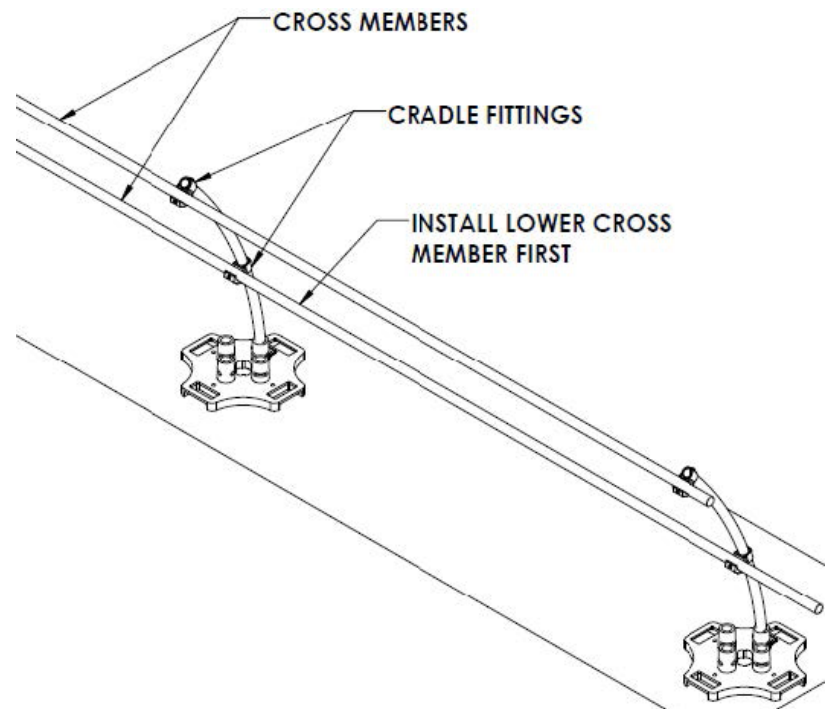
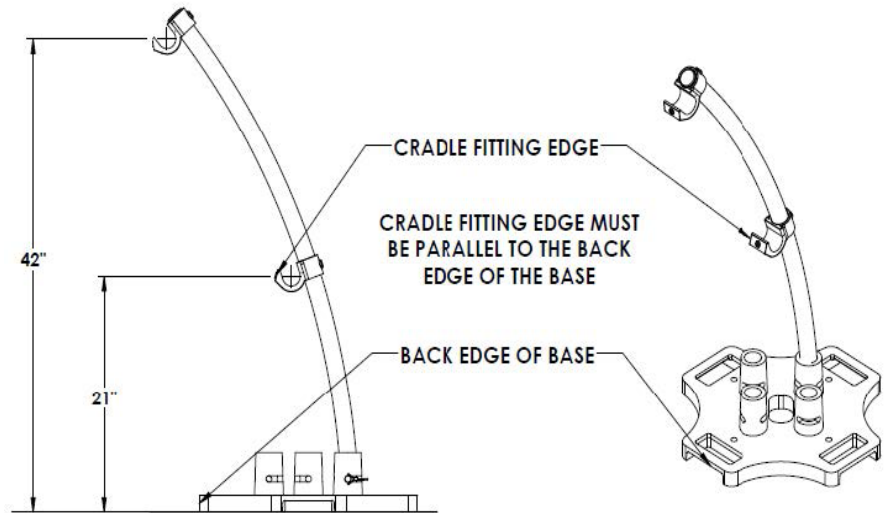

TREMSAFE GUARDRAIL A.S.

INSTALLATION INSTRUCTIONS

8) Place cross members into the cradle fittings set at 21" from the roof top.

9) Place cross members into the cradle fittings set at 42" from the roof top.

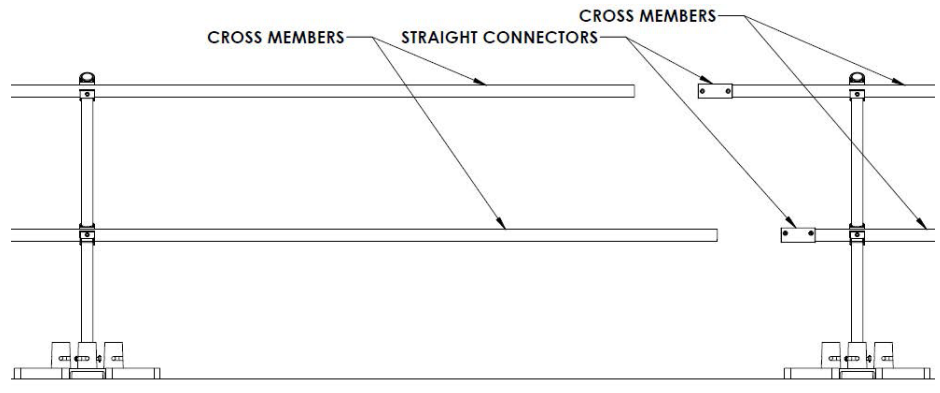

10) If extending cross members, add a straight connector to the ends of the cross members.

a. Ensure that the cross member is inserted no more half way into the straight connector.

b. Tighten the straight connectors to the cross member.

11) Using the next set of cross members, repeat steps 4 through 8.

12) Once assembled, slide the cross members into the straight connectors and tighten the set screws.

13) When cross members exceed the required length, field cut to size.

PLEASE NOTE: Always cut cross members to size prior to installation. Do not attempt to cut the cross member after it has been installed.

14) When a change of direction is required, install 90 degree elbows on the ends of the cross members closest to the corner base.

15) Slide the cross members to be in visual alignment between the fittings and adjacent cross members.

a. For returns, slide the cross member to be in visual alignment with the start end kit fittings.

16) Measure the distance from the installed cross member to the edge of the fitting that will receive the field cut cross member.

a. For returns, measure the distance between the cross member fittings and start end kit fittings.

i. Add 1- $\frac{1}{4}$ " to this measurement to accommodate the inside length of the fitting.

ii. Repeat as required.

17) Install field cut cross members to the fittings and tighten.

18) When the guard rail system is fully installed, ensure that all fittings are secured to the cross.

TREMSAFE GUARDRAIL A.S.

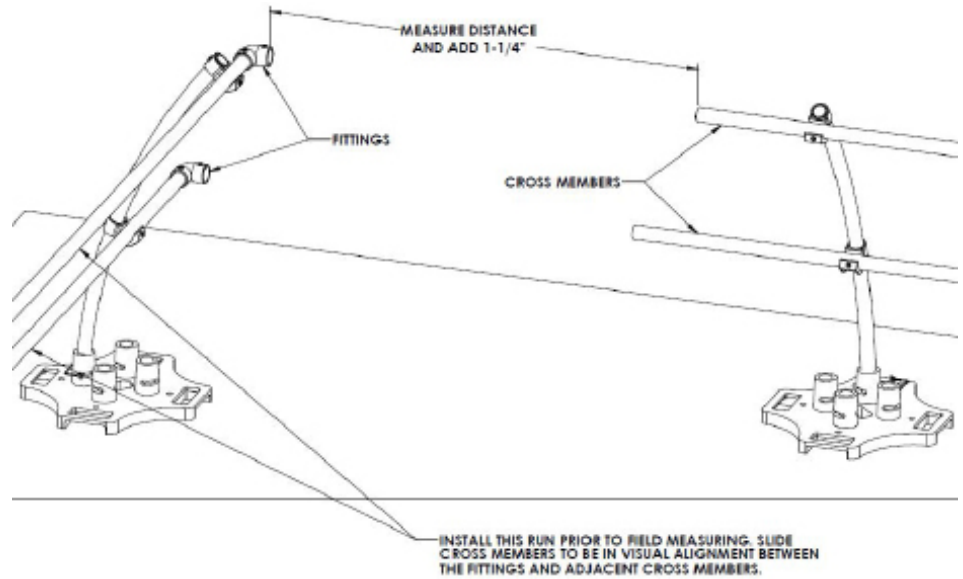

ANNUAL INSPECTION PROCEDURE

- Check for any missing or damaged locking pins, replace if necessary.
- Check for any loose or missing set screws in fittings replace and torque to 24lb-ft.
- Check for damaged rails and stanchions. Replace as necessary



www.tremcoroofing.com
3735 Green Road
Beachwood, Ohio 44122
1.800.852.6013

220 Wicksteed Avenue
Toronto, Ontario M3H 1G7
1.800.668.9879

Tremco Roofing and Building
Maintenance is part of Tremco
Construction Products Group

Tremco is a US Registered trademark of Tremco CPG Inc.

The information provided on this data page supersedes all previous data concerning this product and its application. The Statements provided concerning the materials shown are intended solely as a general guide for material usage and are believed to be true and accurate. Since the manner of use is beyond our control, Tremco DOES NOT MAKE NOR DOES IT AUTHORIZE ANY WARRANTY OF MERCHANTABILITY OR FITNESS FOR ANY PURPOSE, OR ANY OTHER WARRANTY, GUARANTEE OR REPRESENTATION, EXPRESSED OR IMPLIED, CONCERNING THIS MATERIAL EXCEPT THAT IT CONFORMS TO TREMCO'S PRODUCT SAMPLE. Buyer and user accept the product under those conditions and assume the risk of any failure, injury of person or property and loss or liability resulting from the handling, storage or use of the product, whether or not it is handled, stored, used in accordance with directions or specifications. UNDER NO CIRCUMSTANCE SHALL TREMCO BE LIABLE FOR CONSEQUENTIAL OR INCIDENTAL DAMAGES ARISING FROM ANY BREACH OF WARRANTY. IN ALL CASES, TREMCO'S LIABILITY IS LIMITED, AT TREMCO'S OPTION, TO THE REPLACEMENT OF GOODS, OR THEIR VALUE, PROVEN TO BE DEFECTIVE IN MANUFACTURING.